



SDS 6 Power Pak

Made in the U.S.A. since 1939

Direct Drive Gas Driven Vacuum Unit



- Heavy Duty 12 Volt starter, gear reduced for more starting torque.
- Key switch control box with manual pull-start capability.
- Large integral fuel tank.
- 2:1 Gearbox increases torque by two times.
- Centrifugal clutch allows for no load starting and engine to idle without vacuum or water pump operating for longer pump life.
- Automatic oiling system oils pump properly at all vacuum levels and included with the system.
- Use with remote oiler allows for double shaft operation to run auxiliary equipment.
- Heavy duty 3/16" base with beautiful diamond plate trim.
- Integral vacuum relief valve included.

Conde SDS 6 Vacuum Pump

- * 115 CFM Free Air.
- * Double Shaft Design.
- * O-Ring Seals Prevent Leakage.
- * Automatic Oiling, No Adjustment.
- * Low Profile, Mounts Where Others Can't.
- * Sealed Bearings Require No Maintenance.
- * End Thrust Protection.
- * Tangential Rotor Design For Longer Vane Life.
- * ONE YEAR WARRANTY

Honda OHV Gasoline Engines

- * OHV Head Design.
- * Cast Iron Sleeve Cylinder.
- * Ball Bearing Crankshaft.
- * Automatic Oil Alert System Shuts Motor Down When Oil Is Low.
- * Wet Centrifugal Clutch
- * Low Vibration & Noise.
- * Low Maintenance.
- * Easy Starting.
- * Two Year Manufacturer's Warranty.



MANUFACTURERS OF:  VACUUM TECHNOLOGY

DIRECT DRIVEN - CONDE SDS #6 VACUUM (ONLY)

PART# - OLUN06SDS9DD

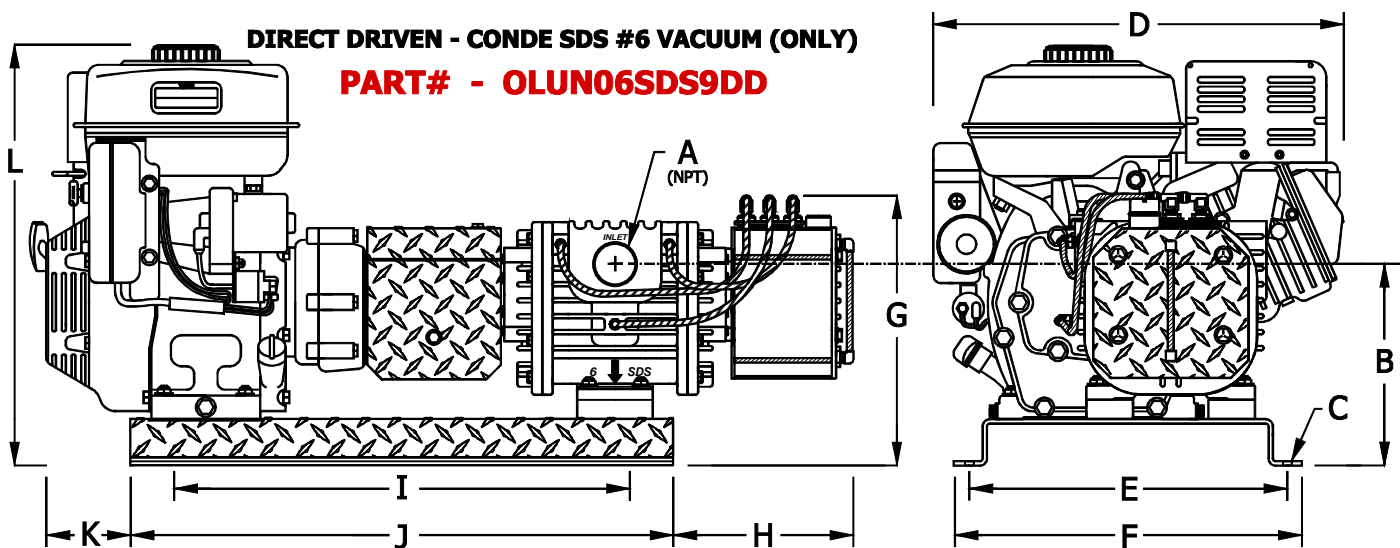

ALL DIMENSIONS IN INCHES

A	B	C	D	E	F	G	H	I	J	K	L
1-1/2	8-1/2	13/32	20	13-3/4	15	11-3/4	8-5/8	19-5/8	23-3/8	4-1/2	18-3/4

WEIGHT - 200 LBS

DIRECT DRIVEN - CONDE SDS #6 VACUUM/PRESSURE

PART# - HDUN06SDS9DD

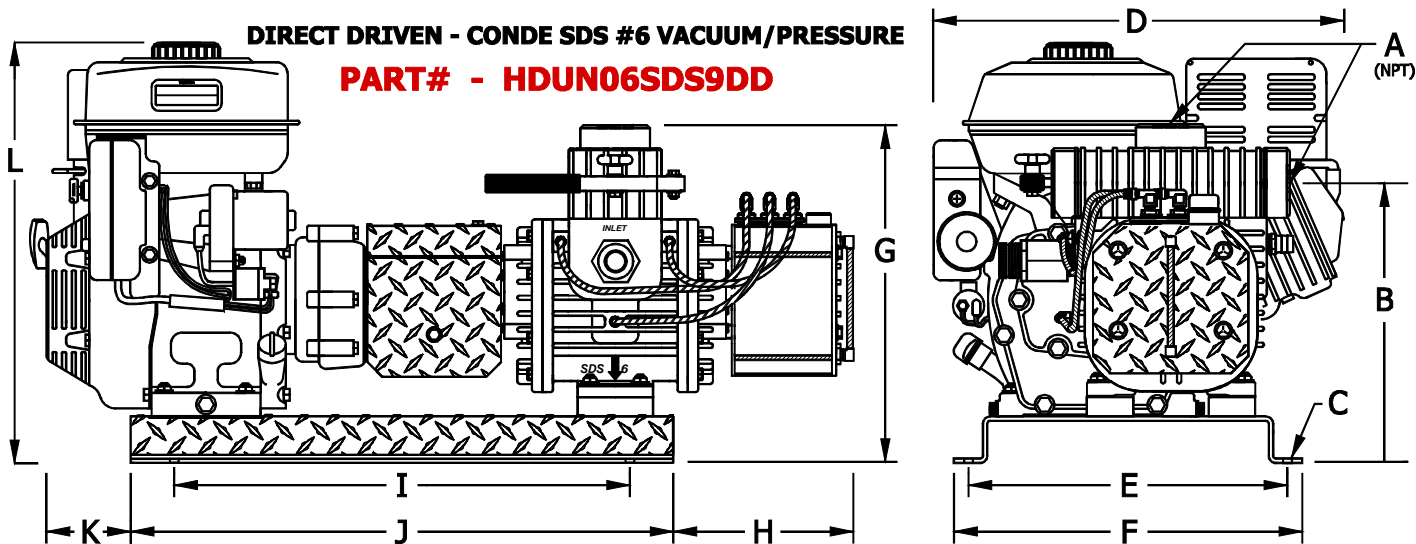

ALL DIMENSIONS IN INCHES

A	B	C	D	E	F	G	H	I	J	K	L
1-1/2	11-7/8	13/32	20	13-3/4	15	14-1/2	8-5/8	19-5/8	23-3/8	4-1/2	18-3/4

WEIGHT - 210 LBS

MOTOR SPECIFICATIONS - HONDA GX270 WITH 2:1 GEARBOX WITH BUILT IN CLUTCH:
 THIS STANDARD FEATURE ON CONDE DIRECT DRIVEN UNIT ALLOWS FOR NO LOAD STARTING AND THE ENGINE TO IDLE WITHOUT THE PUMP IN OPERATION.

WESTMOOR LTD.
906 WEST HAMILTON AVE
SHERRILL, NEW YORK 13461

PHONE: 800-367-0972
FAX: 315-363-0193
VISIT US ONLINE AT WWW.WESTMOORLTD.COM