



ProVac 3 Power Pak

Gasoline Powered Vacuum Units



Made in the U.S.A. since 1939

Conde PowerPak gasoline powered vacuum pump units are compact and available with either Conde vacuum/pressure or vacuum only pumps. Electric or pull start Honda engines can be specified. Standard with compact v-belt drive. Conde PowerPak units are ready to quickly install on your system for your vacuum needs. Quality, reliability, and ease of operation!

Conde ProVac 3 Pump

- * 35 CFM Free Air for tanks to 300 gallons.
- * Double Shaft Design.
- * O-Ring Seals Prevent Leakage.
- * Automatic Oiling, No Adjustment.
- * Low Profile, Mounts Where Others Can't.
- * Sealed Bearings Require No Maintenance.
- * End Thrust Protection.
- * Tangential Rotor Design For Longer Vane Life.
- * ONE YEAR WARRANTY

Honda OHV Gasoline Engines

- * OHV Head Design.
- * Cast Iron Sleeve Cylinder.
- * Ball Bearing Crankshaft.
- * Automatic Oil Alert System Shuts Motor Down When Oil Is Low.
- * Low Vibration & Noise.
- * Low Maintenance.
- * Easy Starting.
- * Two Year Manufacturer's Warranty.

DIMENSIONAL SPECIFICATIONS

CONDE' #3 HD PROVAC GAS UNIT DIMENTIONAL SPECIFICATIONS

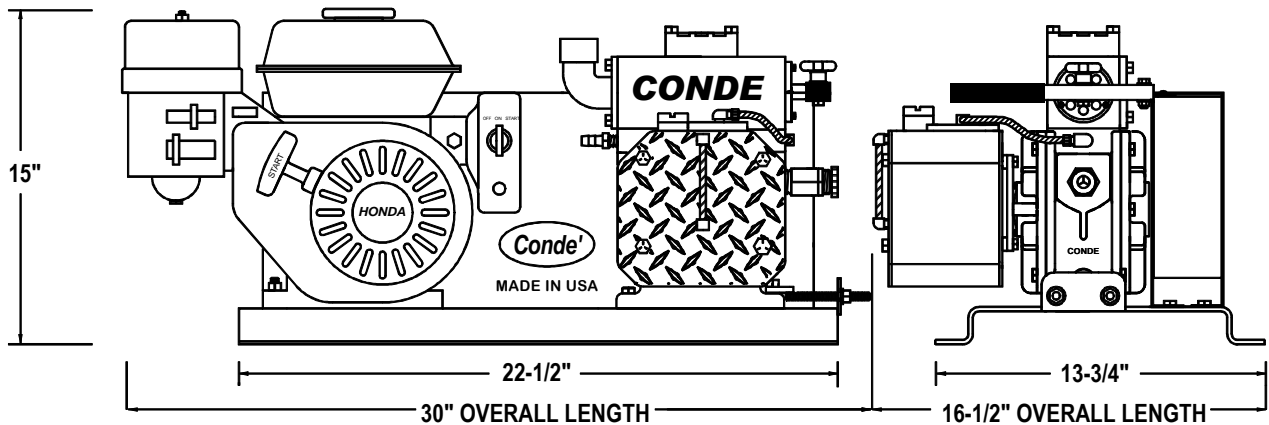

10/24/08

TECHNICAL SPECIFICATIONS

Part No.	OLUN03PV3PS	OLUN03PV05ES
CFM, FREE AIR	35	35
CFM, 15" Hg	17	17
Horsepower	3.0	5.5
Honda El. Start	NO	YES
Vacuum/Pressure	NO	NO
Vacuum Only	YES	YES
Maximum Vacuum	27" Hg	27" Hg
Maximum Pressure*	15 PSIG	15 PSIG
Weight	100 Lbs.	125 Lbs.
Oiler	Automatic	Automatic

* Conde Pumps recommends that pressures on tank systems do not exceed 10 psi. Unit pressure relief vents are set at 5 to 10 psig. Pressure vents will relieve tank pressure when unit is shut off. For higher pressures consult factory.

PERFORMANCE SPECIFICATIONS

Tank Pull Down Time to 15" Hg

TANK SIZE	Model 3 Unit
60 gallons	12 sec.
200 gallons	40 sec.
300 gallons	60 sec.

Conde' Pumps

Westmoor Ltd.

906 West Hamilton Avenue
P.O. Box 99
Sherrill, New York 13461

Phone: 800-367-0972, 315-363-1500

Fax: 315-363-0193

E-Mail: pumps@westmoorltd.com