



## **Super 6 Power Pak**

### **Gasoline Powered Vacuum Units**



Conde PowerPak gasoline powered vacuum pump units are compact and available with either Conde vacuum/pressure or vacuum only pumps. Electric or pull start Honda engines can be specified. Standard with v-belt drive with beautiful diamond plate belt guard and trim. Conde PowerPak units are ready to quickly install on your system for your vacuum needs. Quality, reliability, and ease of operation!

#### **Conde Super 6 Vacuum Pump**

- \*70 CFM Free Air.
- \* Double Shaft Design.
- \* Automatic Oiling, No Adjustment.
- \* Low Profile, Mounts Where Others Can't.
- \* Sealed Bearings Require No Maintenance.
- \* End Thrust Protection.
- \* Tangential Rotor Design For Longer Vane Life.
- \* One Year Warranty

#### **Honda OHV Gasoline Engines**

- \* OHV Head Design.
- \* Cast Iron Sleeve Cylinder.
- \* Ball Bearing Crankshaft.
- \* Automatic Oil Alert System Shuts Motor Down When Oil Is Low.
- \* Low Vibration & Noise.
- \* Low Maintenance.
- \* Easy Starting.
- \* Two Year Manufacturer's Warranty.



# DIMENSIONAL SPECIFICATIONS

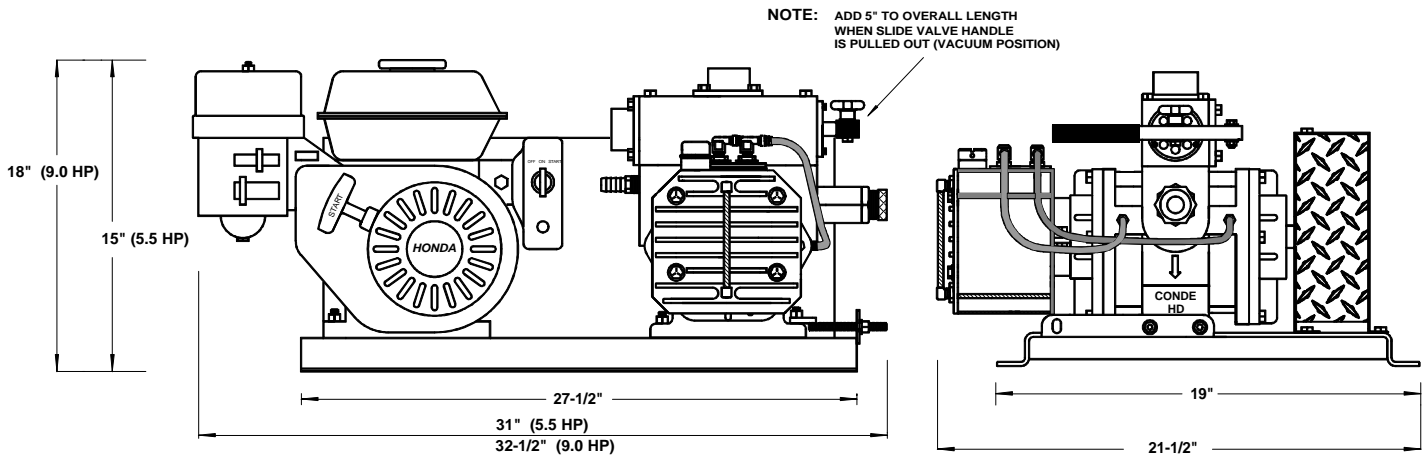

03/29/04  
#6 SUPER - 5.5 HP HONDA ELECTRIC START UNIT

# TECHNICAL SPECIFICATIONS

Part No.	OLUN06SS05ES	HDUN06SS05ES
CFM, FREE AIR	60	60
CFM, 15" Hg	35	35
Horsepower	5.5	5.5
Honda El. Start	YES	YES
Vacuum/Pressure	NO	YES
Vacuum Only	YES	NO
Maximum Vacuum	27" Hg	27" Hg
Maximum Pressure*	15 PSIG	15 PSIG
Weight	155 Lbs.	160 Lbs.
Oiler	Automatic	Automatic

\* Conde Pumps recommends that pressures on tank systems do not exceed 10 psi. Unit pressure relief vents are set at 5 to 10 psig. Pressure vents will relieve tank pressure when unit is shut off. For higher pressures consult factory.

# PERFORMANCE SPECIFICATIONS

Tank Pull Down Time to 15" Hg

TANK SIZE	Super 6, 5.5 HP	Super 6, 9.0 HP
500 gallons	42 sec.	33 sec.
750 gallons	63 sec.	50 sec.
1000 gallons	83 sec.	67 sec.
1500 gallons	125 sec.	100 sec.
2000 gallons	165 sec.	133 sec.

**Conde' Pumps**

**Westmoor Ltd.**

906 West Hamilton Avenue  
P.O. Box 99  
Sherrill, New York 13461

**Phone: 800-367-0972, 315-363-1500**

Fax: 315-363-0193

E-Mail: pumps@westmoorltd.com