



PRO (WHA) ROTARY SEWER NOZZLE USER MANUAL



TABLE OF CONTENTS

MANUFACTURER'S INFORMATION	3
SPECIFICATIONS	3
DESCRIPTION AND INTENDED USE	3
KEY FEATURES	3
EC DECLARATION OF CONFORMITY	4
UK DECLARATION OF CONFORMITY	5
WARNING AND SAFETY INSTRUCTIONS	6
BACKOUT PREVENTION	6
OPERATOR TRAINING RISK ASSESSMENT	7
PPE	8
PRE-RUN SAFETY CHECK	9
WARTHOG® PRO (WHA) OVERVIEW	10
WARTHOG® PRO (WHA) MODEL INFORMATION	11
OPERATION	12
TROUBLESHOOTING	13
VISCOUS FLUID FILL INFORMATION	14
TOOL SERVICE INFORMATION	15
DISASSEMBLY	16
ASSEMBLY	20
WARTHOG® PRO (WHA) MAINTENANCE SCHEDULE	24
WARTHOG® PRO (WHA) SERVICE KITS	25
TERMS AND CONDITIONS AND WARRANTY	26

StoneAge Inc.
466 S. Skylane Drive
Durango, CO 81303, USA
Phone: 970-259-2869
Toll Free: 866-795-1586
www.stoneagetools.com

StoneAge NL
Reedijk 7Q
3274 KE Heinenoord
Netherlands
(+31) (0) 85 902 73 70
sales-NL@stoneagetools.com

StoneAge UK
Unit 3
Crucible Business Park
Woodbury Lane
Norton
Worcester
Worcestershire, WR5 2DQ
United Kingdom
+44 (0) 1684 892065
sales-eu@stoneagetools.com

This manual must be used in accordance with all applicable national laws. The manual shall be regarded as a part of the machine and shall be kept for reference until the final dismantling of the machine, as defined by applicable national law(s). Updated manuals can be downloaded at:

<https://www.stoneagetools.com/manuals>

Warthog® PRO (WHA) SPECIFICATIONS	
Tool Models:	WHA-3/4 & WHA-1
Pipe Size:	6-18 in. (150-450 mm)
Pressure Range:	1200-8000 psi (83-550 bar)
Flow Range:	20-70 gpm (76-260 Lpm)
Flow Coefficient:	2.6 Cv
Viscous Service Life	60 Hours
Rotation Speed:	150-450 rpm
Inlet Connection:	3/4" NPT or BSPP & 1" NPT or BSPP
Jet Port Size:	5 x 1/8" NPT
Jet Type:	CNP2
Port Plug Type:	AP2 002
Outside Diameter:	3.4 in. (86 mm)
Overall Length:	7.7 in. (200 mm)
Weight:	5 lbs (2.3kg)
Max Water Temperature:	160 °F (70 °C)

DESCRIPTION OF EQUIPMENT AND INTENDED USE

This nozzle is designed to clean and clear pipes between 6-18" (152-457 mm). Controlled rotation technology allows the jets to deeply penetrate through the toughest deposits.

Plus, additional head options deliver even more pulling and descaling power. The Warthog® PRO (WHA) is most commonly used with small capacity combination trucks and large trailer jetters.

KEY FEATURES:

- Engineered to handle recycled water
- New 4-fin centralizer design allows steeper rear jets for more powerful pulling and flushing
- New access ports enable viscous fluid change without disassembly for easy field maintenance



EC DECLARATION OF CONFORMITY

Manufacturer: StoneAge Incorporated
466 South Skylane Drive Durango, CO 81303 USA

Authorized Representative: StoneAge Netherlands BV
Reedijk 7Q
3274 KE Heinenoord Netherlands
Sander de Korte, Customer Service Manager

Declare that: Warthog® Pro (WHA)
are rotary swivel tools designed for cleaning sewer pipes.

Are compliant with the following Directives and Standards:

Directive 2006/42/EC (Machinery Directive)
EN ISO 12100:2010 (E) Safety of machinery – General principles for design – Risk assessment and risk reduction

The Technical Files for the Warthog® Pro (WHA) are maintained at:

StoneAge Incorporated, 466 South Skylane Drive, Durango, CO 81303, USA and were compiled by the Engineering Manager. The Technical File is available through the Authorized Representative. This Declaration of Conformity is issued under the exclusive responsibility of StoneAge Incorporated.



StoneAge Incorporated, Durango, CO, USA
Liz Mancuso, Director of Engineering

02/15/23
Date

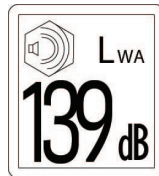

UK DECLARATION OF CONFORMITY

Manufacturer: StoneAge Incorporated
466 South Skylane Drive Durango, CO 81303 USA

Authorized Representative: StoneAge UK
Unit 3
Crucible Business Park
Woodbury Lane
Norton
Worcester
Worcestershire, WR5 2DQ
United Kingdom
Steve Ellis, Managing Director StoneAge UK

Declare that: Warthog® Pro (WHA)
are rotary swivel tools designed for cleaning sewer pipes.

Are compliant with the following Statutory Requirements and Designated Standards:

S.I. 2008 No. 1597 (E) Safety of machinery – General principles for design – Risk assessment and risk reduction
EN ISO 12100:2010 (E) Safety of machinery – General principles for design – Risk assessment and risk reduction

The Technical Files for the Warthog® Pro (WHA) are maintained at:

StoneAge Incorporated, 466 South Skylane Drive, Durango, CO 81303, USA and were compiled by the Engineering Manager. The Technical File is available through the Authorized Representative. This Declaration of Conformity is issued under the exclusive responsibility of StoneAge Incorporated.



StoneAge Incorporated, Durango, CO, USA
Liz Mancuso, Director of Engineering

02/15/23
Date

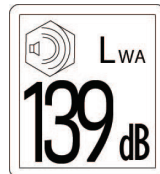

**UK
CA**

WARNING AND SAFETY INSTRUCTIONS

⚠ WARNING

Because of the short length of the Warthog® Pro (WHA), the tool can turn around in pipes and come back at the operator at a high rate of speed. There must be an anti-reversal device of sufficient length to ensure that the rigid length measurement from the tip of the nozzle to the back end of the hose crimp is 1-1/2 times the internal diameter of any pipe that can be accessed in the cleaning operation. A rigid “stinger” should be used between the hose and the tool. (see below)

Operators **MUST** read, understand, and follow the Operational Procedures (Section 9.0) of WJTA-IMCA's, Industry Best Practices For The Use Of High-pressure Waterjetting Equipment, or equivalent. Make sure there is an operator controlled dump in the system, operated by the person closest to the cleaning job. It is recommended that the hose be marked a few feet from the end with a piece of tape so the operator knows when to stop when retracting the tool.

⚠ DANGER

Operations with this equipment can be potentially hazardous. Caution must be exercised prior to and during machine and water jet tool use. Please read and follow all of these instructions, in addition to the guidelines in the WJTA Recommended Practices handbook, available online at www.wjta.org. Deviating from safety instructions and recommended practices can lead to severe injury and/or death.

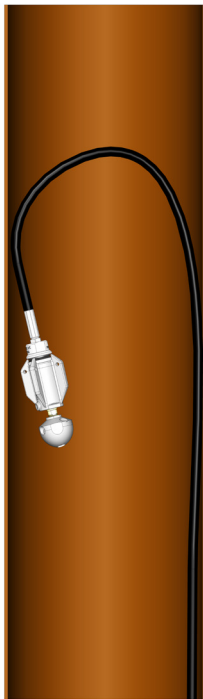

IMPROPER USE:
PRO (WHA) will turn around in large diameter pipe
VERY DANGEROUS!

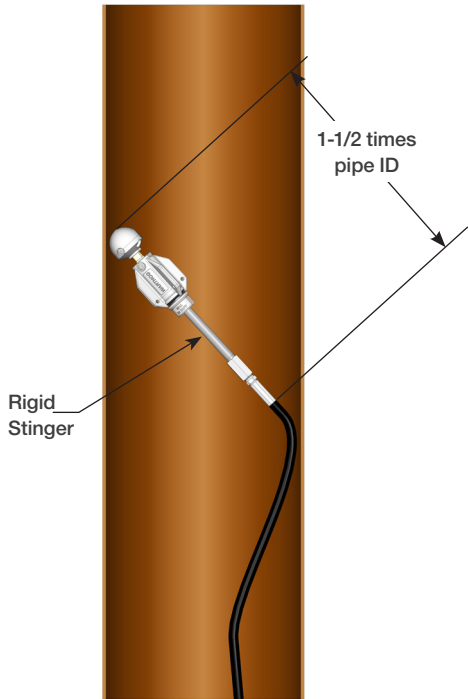

PROPER USE:
PRO (WHA) with rigid “stinger” to prevent turnaround, still able to pass through elbows.

WARNING AND SAFETY INSTRUCTIONS

OPERATOR TRAINING

Managers, Supervisors, and Operators **MUST** be trained in Health and Safety Awareness of High-pressure Water Jetting and hold a copy the Water Jetting Association (WJA) Code of Practice, or equivalent (see www.waterjetting.org.uk).

Operators **MUST** be trained to identify and understand all applicable standards for the equipment supplied. Operators should be trained in manual handling techniques to prevent bodily injury.

StoneAge has designed and manufactured this equipment considering all hazards associated with its operation. StoneAge assessed these risks and incorporated safety features in the design. StoneAge **WILL NOT** accept responsibility for the results of misuse.

IT IS THE RESPONSIBILITY OF THE INSTALLER/ OPERATOR to conduct a job specific risk assessment prior to use. Job specific risk assessment **MUST** be repeated for each different set up, material, and location.

The risk assessment **MUST** conform to the Health and Safety at Work Act 1974 and other relevant Health and Safety legislation.

Operators **MUST** read, understand, and follow the Operational and Training Requirements (Section 6.0) of WJTA-IMCA's, Industry Best Practices For The Use Of High-pressure Waterjetting Equipment, or equivalent.

Operators **MUST** read, understand and follow the Warnings, Safety Information, Assembly, Installation, Connection, Operation, Transport, Handling, Storage, and Maintenance Instructions detailed in this manual.

The risk assessment **MUST** consider potential material or substance hazards including:

- Aerosols
- Biological and microbiological (viral or bacterial) agents
- Combustible materials
- Dusts
- Explosion
- Fibers
- Flammable substances
- Fluids
- Fumes
- Gases
- Mists
- Oxidizing Agents



WARNING AND SAFETY INSTRUCTIONS

PERSONAL PROTECTIVE EQUIPMENT REQUIREMENTS

Use of Personal Protective Equipment (PPE) is dependent on the working pressure of water and the cleaning application. Managers, Supervisors, and Operators **MUST** carry out a job specific risk assessment to define the exact requirements for PPE. See Personal Protective Equipment (Section 5) of WJTA-IMCA's, Industry Best Practices For The Use Of High-pressure Waterjetting Equipment for additional information.

Hygiene - Operators are advised to wash thoroughly after all waterjetting operations to remove any waterblast residue which may contain traces of harmful substances.

First aid provision - users **MUST** be provided with suitable first aid facilities at the operation site.

PPE may include:

- **Eye protection:** Full face visor
- **Foot protection:** Kevlar® brand or steel toe capped, waterproof, non-slip safety boots
- **Hand protection:** Waterproof gloves
- **Ear protection:** Ear protection for a minimum of 85 dBA
- **Head protection:** Hard hat that accepts a full face visor and ear protection
- **Body protection:** Multi-layer waterproof clothing approved for waterjetting
- **Hose protection:** Hose shroud
- **Respiratory protection:** May be required; refer to job specific risk assessment



WARNING AND SAFETY INSTRUCTIONS

⚠ WARNING

Operations with this equipment can be potentially hazardous. Caution **MUST** be exercised prior to and during equipment and water jet tool use. Please read and follow all of these instructions, in addition to the guidelines in the WJTA-IMCA's Industry Best Practices handbook, available online at www.wjta.org. Deviating from safety instructions and recommended practices can lead to severe injury and/or death.

- Do not exceed the maximum operating pressure specified for any component in a system.
- The immediate work area **MUST** be marked off to keep out untrained persons.
- Inspect the equipment for visible signs of deterioration, damage, and improper assembly. Do not operate if damaged, until repaired.
- Make sure all threaded connections are tight and free of leaks.
- Users of the Warthog® PRO (WHA) **MUST** be trained and/or experienced in the use and application of high-pressure technology and cleaning, as well as all associated safety measures, according to the WJTA Recommended Practices for the use of High-pressure Waterjetting Equipment.
- Install mechanical stops, stingers and back out preventers as appropriate when doing any tube, pipe or vessel cleaning.
- Always de-energize the system before servicing or replacing any parts. Failure to do so can result in severe injury and/or death.

Refer to WJTA-IMCA's Industry Best Practices For The Use Of High-pressure Waterjetting Equipment and/or The Water Jetting Association's, WJA Code of Practice for additional safety information.

- Complete a job specific risk assessment and act on the resulting actions.
- Adhere to all site specific safety procedures.
- Ensure the waterblasting zone is properly barricaded and that warning signs are posted.
- Ensure the workplace is free of unnecessary objects (e.g. loose parts, hoses, tools).
- Ensure all Operators are using the correct Personal Protective Equipment (PPE).
- Check that the air hoses are properly connected and tight.
- Check all hoses and accessories for damage prior to use. Do not use damaged items. Only high quality hoses intended for waterblast applications should be used as high-pressure hoses.
- Check all high-pressure threaded connections for tightness.
- Operate the high-pressure water at full pressure and use the Pneumatic Foot Pedal Dump Control to verify that the dump valve is working properly.
- Ensure that Operators never connect, disconnect, or tighten hoses, adapters, or accessories with the high-pressure water pump unit running.
- Ensure no personnel are in the hydroblasting zone.

PRE-RUN SAFETY CHECK

WARTHOG® PRO (WHA)

PIPE SIZE: 6-18" | 152-457 mm
INLET: 3/4" & 1" NPT or BSPP
FLOW RATE: 20-70 gpm | 76-260 lpm
SERVICE INTERVAL: 50-60 hours

Ideal for municipal and industrial sewer cleaning professionals who need specialized jetting for specific applications and upgraded components engineered for handling recycled water and extra durability.

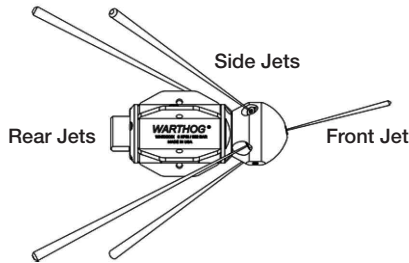

DESCALER

- Jetting is configured with more force to the side jets for cleaning and polishing
- Side jets are angled to reduce stand-off distance to the pipe wall, while delivering intense jet impact to remove tough build up, calcium deposits, and scaling with ease.
- Uses durable carbide jets for extended service life

WHA DESCALER

5 Ports:

Front: 1 @ 15°
Side: 2 @ 105°
Rear: 2 @ 150°

DESCALING



PULLING/
FLUSHING



PULLER/DESCALER

- Jetting is configured with more force to the side jets for cleaning and polishing and to the rear jets for extra pulling power
- Side jets are angled to reduce stand-off distance to the pipe wall, delivering intense jet impact to remove tough build up, calcium deposits, and scaling with ease
- Rear jets are angled further back to increase pulling power for long runs and climbs, and max flushing capability

WHA PULLER /DESCALER

5 Ports:

Front: 1 @ 15°
Side: 2 @ 105°
Rear: 2 @ 162°

DESCALING



PULLING/
FLUSHING



Warthog® PRO (WHA) MODEL INFORMATION

RECOMMENDED HOSES

WHA-3/4: StoneAge recommends a 3/4" ID hose be used, especially when using longer hose lengths.

WHA-1: StoneAge recommends a 1" ID hose be used, especially when using longer hose lengths.

JETTING

Pumps are commonly sold based on their *theoretical* maximum flow output; in reality, none are 100% efficient. We try to take this into account when supplying you the jets. If you are not getting to the operating pressure desired, the sizes of the jets may need to be changed.

The table below is provided as an overview of common jetting parameters. For more precise jetting information, please use the StoneAge Jetting App to determine jet sizes:

jetting.stoneagetools.com

For more information regarding the Warthog® PRO (WHA) or other Warthog® Sewer Tools, contact your factory authorized Warthog® Distributor or go to:

www.sewernozzles.com

Warthog® PRO (WHA) HEAD OFFSET CHART

WHA WITH 500' OF Ø3/4" HOSE		PRESSURE						
		2000 PSI	2500 PSI	3000 PSI	3500 PSI	4000 PSI	4500 PSI	
FLOW	GPM	L/MIN	140 BAR	170 BAR	210 BAR	240 BAR	280 BAR	310 BAR
	20	76	R40	R40	R40	R40	R40	R40
	30	110	R40	R30	R30	R30	R22	R22
	40	150	R30	R30	R30	R22	R22	R22
	50	190	N/A	R30	R22	R15	R15	R15
WHA WITH 500' OF Ø1" HOSE		PRESSURE						
		2000 PSI	2500 PSI	3000 PSI	3500 PSI	4000 PSI	4500 PSI	
FLOW	GPM	L/MIN	140 BAR	170 BAR	210 BAR	240 BAR	280 BAR	310 BAR
	20	76	R40	R40	R40	R40	R40	R40
	30	110	R30	R30	R30	R22	R22	R22
	40	150	R30	R22	R22	R22	R22	R15
	50	190	R22	R22	R15	R15	R15	R15
	60	230	R22	R15	R15	R15	R15	N/A
70	260	R22	R15	R15	N/A	N/A	N/A	
WHA PULLER WITH 500' OF Ø3/4" HOSE		PRESSURE						
		2000 PSI	2500 PSI	3000 PSI	3500 PSI	4000 PSI	4500 PSI	
FLOW	GPM	L/MIN	140 BAR	170 BAR	210 BAR	240 BAR	280 BAR	310 BAR
	20	76	N/A	N/A	N/A	N/A	N/A	N/A
	30	110	N/A	N/A	R22	R22	R22	R22
	40	150	N/A	R22	R22	R22	R15	R15
	50	190	N/A	R22	R22	R15	R15	R15
WHA PULLER WITH 500' OF Ø1" HOSE		PRESSURE						
		2000 PSI	2500 PSI	3000 PSI	3500 PSI	4000 PSI	4500 PSI	
FLOW	GPM	L/MIN	140 BAR	170 BAR	210 BAR	240 BAR	280 BAR	310 BAR
	20	76	N/A	N/A	N/A	N/A	N/A	N/A
	30	110	N/A	N/A	R22	R22	R22	R22
	40	150	R22	R22	R15	R15	R15	R15
	50	190	R15	R15	R15	R15	R15	R15
	60	230	R15	R15	R15	R15	N/A	N/A
	70	260	R22	R15	R15	N/A	N/A	N/A

⚠ DANGER

Do not attempt to clean a manhole with the WHA hanging by the hose. The tool can turn around and strike the Operator. Specific accessories are offered and are required to safely clean manholes. Do not allow the tool to enter a manhole or vault while in operation. If the tool is not contained in a pipe it presents a serious hazard and if not avoided could result in death or serious injury.

NOTE: A 15-25 foot long section of leader hose of a different color than the jetter hose is recommended to indicate how close the tool is to exiting the pipe.

- Flush the jetter hose prior to installing the nozzle to remove debris. Install the hose guard or Tiger Tail. If the WHA is being used in pipe diameters less than 10 inches it can be attached directly to the hose end. If being used in larger pipes a straight rigid pipe or centralizer must be placed behind the tool such that the rigid length is greater than the pipe diameter to ensure the tool cannot turn around in the pipe.
- To clean lines, position the WHA and Tiger Tail so it can enter the pipe to be cleaned. The recommended cleaning direction is upstream from the manhole.
- Slowly bring the pump up to pressure, making certain that the WHA begins to pull its way into the pipe in the proper direction; allow it to advance a few feet and note the location of the leader hose or other hose marker being used. Once the pump is up to operating pressure, feed out the reel at a reasonable rate to allow the jets time to clean the pipe.
- If roots are present, feeding at a slower rate will improve the cleaning results. Depending on the amount of debris in the pipe, it may be necessary to occasionally pull the WHA back toward the manhole to prevent buildup of debris behind the tool.
- When finished cleaning, withdraw the tool back to its initial starting point noted by the location of the leader or hose marker.
- Shut down and secure the pump before removing the WHA from the line.
- After the job has been completed, remove the WHA from the hose and blow out the water with compressed air to prolong the life of the internal components.

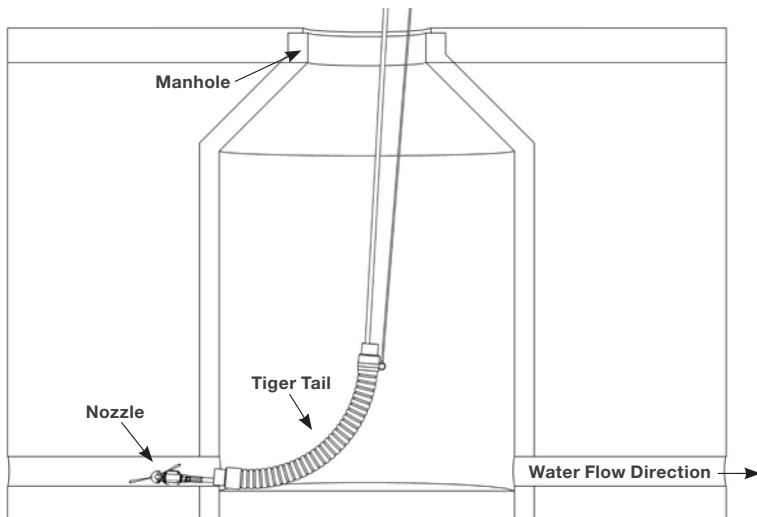

Figure 1. Proper Nozzle Setup

HEAD WILL NOT ROTATE:

- Check to see if any jets, or inserts, are plugged. Even if a jet is only partially blocked it can keep the head from rotating. Jets must be removed from the head to be properly cleaned. Poking the material plugging the jet back into the head will not fix the problem because it will re-plug the jet once water starts flowing. If the jets are all clear, wash the nozzle off with water to remove any debris or grit between the head, body and shaft. Then try rotating head by hand. It should feel free with a slight amount of smooth resistance. If it feels rough, gritty, or hard to turn, the tool needs to be repaired. It may need new bearings and shaft seals or high pressure seals. It is possible the tool needs viscous fluid added or changed, but if viscous fluid is confirmed to be present, a rebuild should be considered.

HEAD SPINS TOO FAST:

- If the nozzle is spinning significantly faster than normal, or if the nozzle starts to sound different (like a jet engine or a turbo charger) the nozzle may be low on viscous fluid, or the viscous fluid may be contaminated. In this case, add or change the fluid as appropriate. Continued operation in this state can mechanically damage the tool and a rebuild may be required to replace the faulty shaft seals.

HIGH-PRESSURE WATER SEALS LEAK:

- The WHA's seal design uses a slight amount of water for lubrication. At full pressure it should not leak more than a few drops with a new set of seals. The high pressure seals may need to be replaced if you are not able to get to full pressure or when a continuous spray comes from inlet nut.

LOCK-UP TROUBLESHOOTING TIP:

- Rotate in reverse 1 1/4 to 1 1/2 turns to unlock braking mechanism. If tool rotates smoothly then redress may not be required.
- If the head rotates freely by hand, check the jet sizes and calculate pressure loss through the coil tubing and check with your distributor or StoneAge® to make certain there is enough jet torque to provide rotation.
- Verify jetting at <http://jetting.stoneagetools.com/#/t/sw> contact your factory authorized Warthog® dealer or contact StoneAge®, Inc.

TO KEEP THE TOOL RUNNING AT ITS BEST, PLEASE FOLLOW THE MAINTENANCE SCHEDULE IN THIS MANUAL

FLUID REPLACEMENT

SPEED CONTROL FLUID CHANGE

Fluid replacement is made easy with the WHA. Disassembly of the tool is not required, which means there is less chance for contamination and longer overall tool life. Fluid changes should be performed by qualified persons.

This procedure is recommended for replacing the fluid with the same viscosity.

Not all of the fluid will be replaced using this procedure. Full disassembly and cleaning is recommended when changing speed, or viscosity of fluid. The WHA is designed for maximum fluid life and frequent fluid changes should not be required. A complete fluid change is necessary when replacing bearings and shaft seals.

NOTICE

Improper fluid change maintenance can result in reduced bearing or shaft seal life. Use extreme care when performing this procedure. The fluid is thick and only very light pressure should be applied to the syringe. Excess pressure will force fluid past the inner shaft seals and into the bearings.

VISCOUS FLUID REPLACEMENT INSTRUCTIONS

1. Position the tool (preferably mounted in a vise) at an angle with one Port Plug (BJ 026) at the highest point and the other Port Plug at the lowest point. Clean around, then remove the upper Port Plug from the body.
2. Fill the Syringe (BC 410) with viscous fluid by removing the end near the handle, pulling out the plunger, and pouring the Viscous Fluid (BJ 048-M) in to fill the Syringe Body. With plunger re-installed, purge air out of Syringe hose.
3. Screw the syringe into the upper port, then remove the lower Port Plug. Using the assistance of gravity, gently ease the new fluid into the WHA Body while letting the old fluid flow out the opposite hole.
4. Rotate the Head Clockwise while flushing. **DO NOT PRESSURIZE THE CHAMBER** by aggressively forcing in fluid. The fluid is thick and some time is required to complete the flush.
5. Reinstall the exit Port Plug, then remove the Syringe and install the inlet Port Plug.

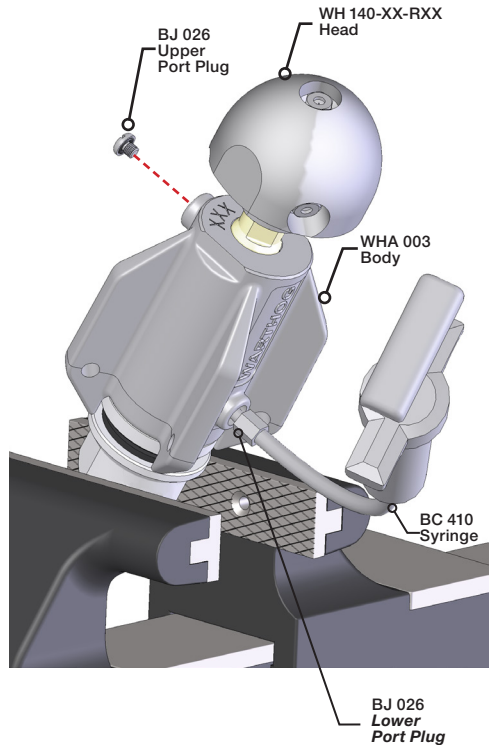

Product training and proper tools are required to service this nozzle. If you are uncomfortable performing the service, bring the nozzle to your authorized dealer.

The use of a bench vise and an arbor press is recommended. Take care throughout the entire procedure to keep the internals clean and free from grit, lint, and contamination. Failure to do so could result in premature failure after service. See complete Disassembly and Assembly instructions in this manual.

NECESSARY TOOLS:

- Arbor Press (recommended)
- Bench vise (recommended)
- Large Adjustable Wrench (12" Crescent® Wrench)
- Medium size flat-head screw driver
- Pick

NECESSARY MATERIALS:

- Clean lint free rags or blue shop towels
- Isopropyl Alcohol
- Anti-Seize - Swagelok® Blue Goop® StoneAge PN (GP 043)
- Grease - P80 Grip-IT® Lubricant StoneAge PN (GP 038-X)
- Grease - Chevron Multifak® EP1 StoneAge PN (GP 049)
- When installing jets, StoneAge uses Parker® Yellow ThreadMate and Teflon Tape or an equivalent combination on the threads of each jet.

WHA 612 TOOL KIT (INCLUDES)

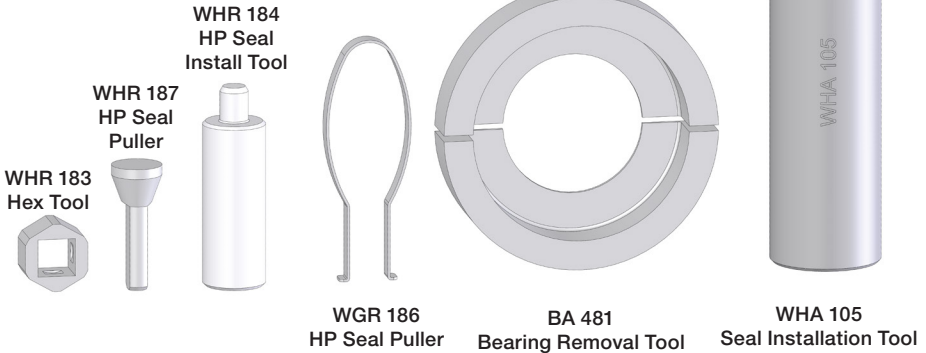

Blue Goop® is a registered trademark of Swagelok® Company.

P-80 Grip-it® Quick-Drying Temporary Lubricant - International Products Corporation.

Parker® Yellow ThreadMate™ is a registered trademark of Parker-Hannifin Corporation.

Chevron® and Multifak® EP 1 are registered trademarks and/or trademarks of Chevron® USA Inc.

DISASSEMBLY

DISASSEMBLY

1. Remove the head by clamping it in a bench vise with the Inlet Nut facing up. Grip the Shaft flats with an adjustable end wrench or a 14mm open end wrench, and loosen the WHA Assembly from the head and continue removing by hand.

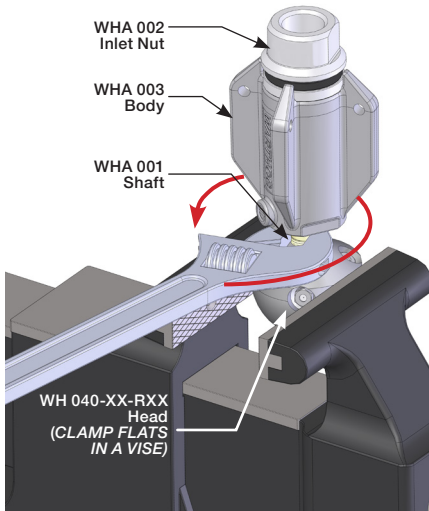

Figure 1: For Step 1

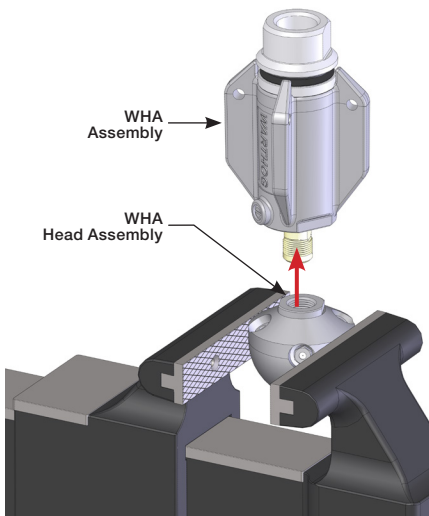

Figure 2: For Step 1

2. Clamp the flats on the Body in the vise. Use caution not to deform the Body with too much pressure.
3. Use a Large Adjustable Wrench to remove the Inlet Nut from the Body and set the Inlet Nut assembly aside.

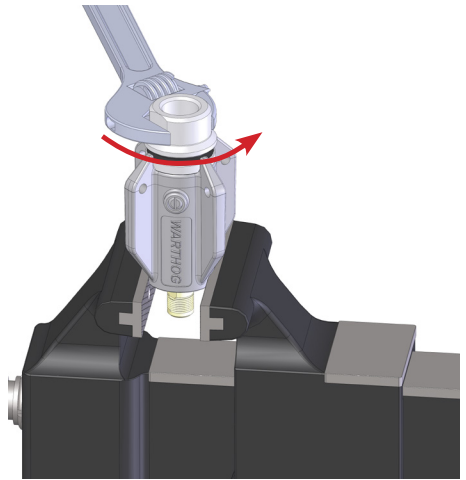

Figure 3: For Steps 2-3

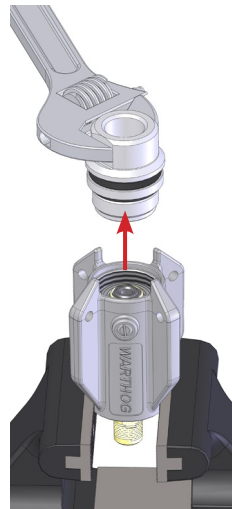

Figure 4: For Steps 2-3

- Remove the assembly from the vise.
- Flip the assembly 180° and unscrew one of the BJ 026 Port Plugs to release the vacuum inside the body and let the shaft assembly slide out of the Body.

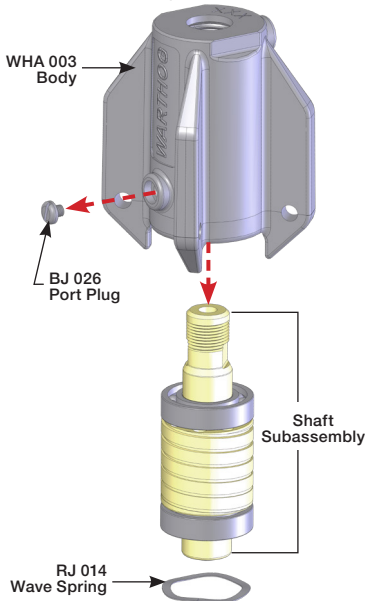

Figure 5: For Steps 4-5

- Squeeze the HP Seal Puller together and insert it into the bore of the Shaft HP Seal, then release. The HP Seal Puller should hook the bottom edge of the Shaft HP Seal; pull upward in a circular pattern to work the Shaft HP Seal out of the Shaft.

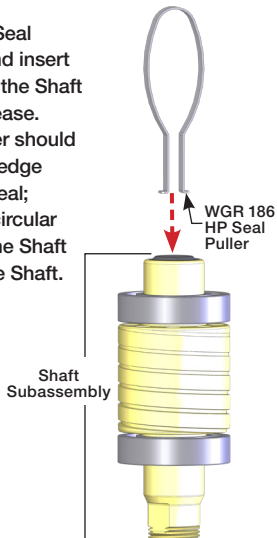

Figure 6: For Step 6

- Remove the Wave Spring. *Removing the Shaft HP Seal is required to prevent it from being damaged*
- Use a pick to remove the O-Ring from the Shaft. Do not scratch the glands in the shaft otherwise leakage may occur.

While removing the Bearing in the next step. Inspect the polished faces, if damaged, replace HP Seal set and together.

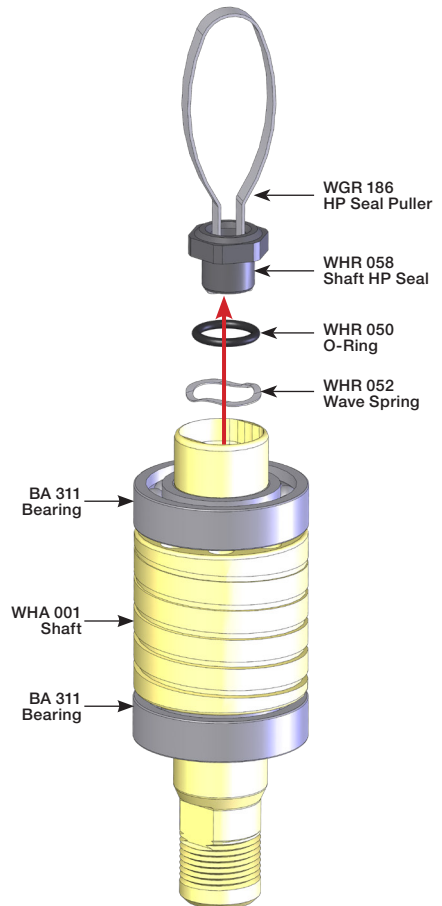

Figure 7: For Steps 7-8

9. Remove the Shaft Seal from the Body with a pick.

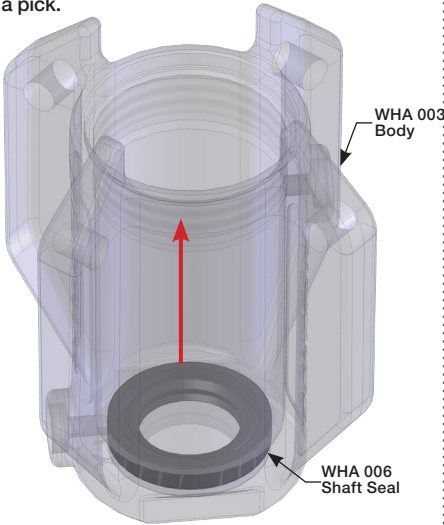
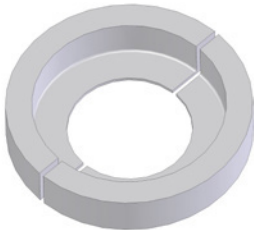

Figure 8: For Step 9

10. Evenly seat a Bearing Splitter under the Rear Bearing then press on the end of the Shaft to remove Bearing.



Bearing Splitter BA 481
*Included in WHA 612 Tool Kit

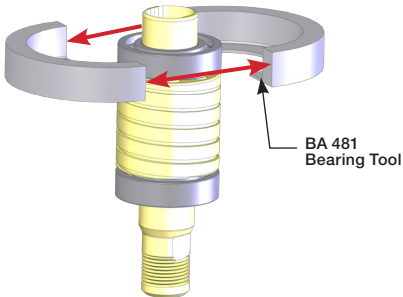

Figure 9: For Step 10

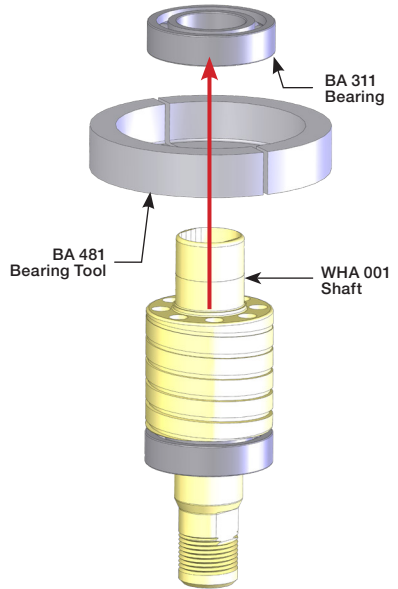

Figure 10: For Step 10

11. Then flip the Shaft and repeat the process to remove the second Bearing.

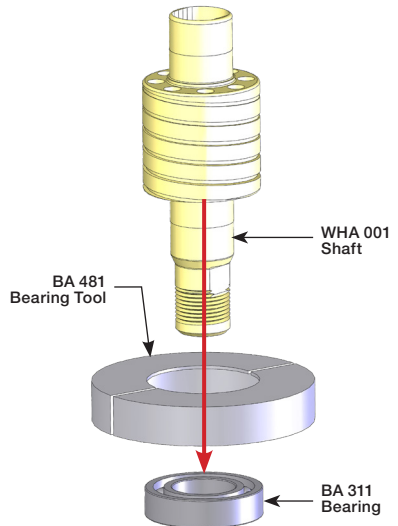

Figure 11: For Step 11

12. Inspect the Shaft for grooving where the shaft seals and bearing ride for signs of the bearings slipping or scratches which extend into the area where the seals operate. Remove burrs or high spots by gently grinding or filing. If any place is severely damaged or worn, the shaft may need to be replaced.

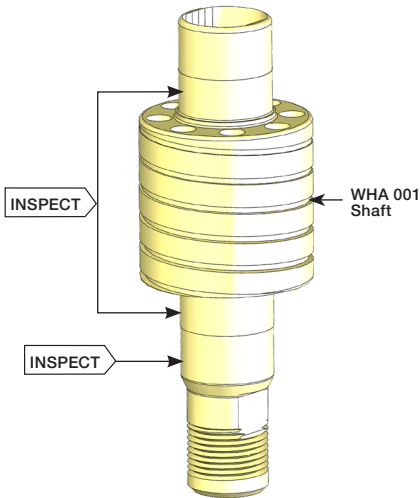

Figure 12: For Step 12

13. Using a pick, remove the Shaft Seal and both O-Rings from the Inlet Nut. Use care to not scratch or damage the seal bore or glands of the Inlet Nut otherwise leakage may occur.
14. Squeeze the HP Seal Puller together and insert it into the bore of the Nut HP Seal, then release. The HP Seal Puller should hook the bottom edge of the Nut HP Seal; pull upward in a circular pattern to work the Nut HP Seal out of the Inlet Nut. Using a pick remove the Wave Spring and O-Ring. Inspect the polished faces, if damaged, replace HP Seal set together.

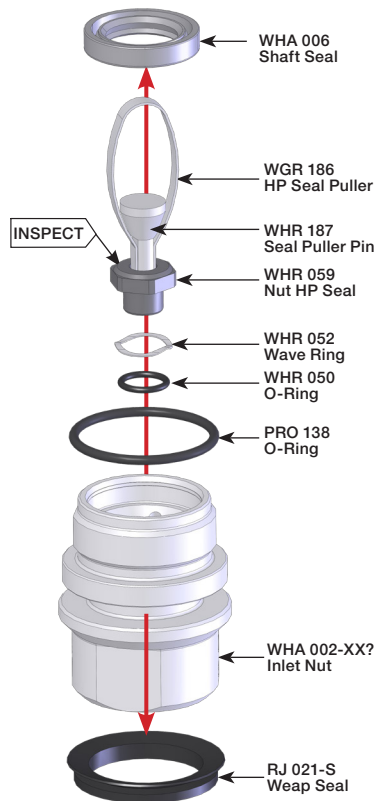

Figure 13: For Steps 13-14

ASSEMBLY

NOTICE

Wash all appropriate parts in solvent and blow dry before assembling. Always use the new replacement parts from our service kits. See the "Service Kit" section of this manual for a list of available replacement parts.

- GREASE 1** = Chevron Multifak® EP 1
- GREASE 2** = P80 Grip-IT® Lubricant
- ANTI-SEIZE** = Swagelock® Blue Goop or Equal

1. Install the O-Ring into the recess inside the bore of the Inlet Nut. Apply grease after it is seated in the recess. Then place the Wave Spring into the Inlet Nut.
2. Apply a light coating of grease to the stem of the Nut HP Seal. Using the HP Seal Press (WHR 184) gently press the Nut HP Seal into the Inlet Nut. Rocking the Nut HP Seal in a small circular pattern while applying light pressure may aid in installation. **Pressing too hard will damage or chip the seal. Always use the Seal Install Tool to avoid damage to the polished face.* The Nut HP Seal should compress freely*

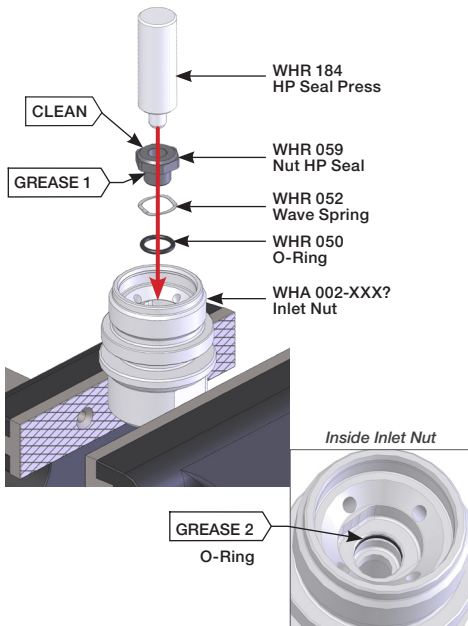

Figure 14: For Steps 1-2

3. Use the WHA 105 Seal Press to install the Shaft Seal with the lip spring facing UP away from the Inlet Nut. Generously coat the inside of the Shaft Seal with grease.
4. Install the O-Ring (PRO 138) seats around the base of the threads.
5. Grease the Weep Seal (RJ 021-S) and install wide flange side facing UP toward the Inlet Nut.
6. Apply anti-seize to the threads of the Inlet Nut. StoneAge recommends Blue Goop® (GP 043).

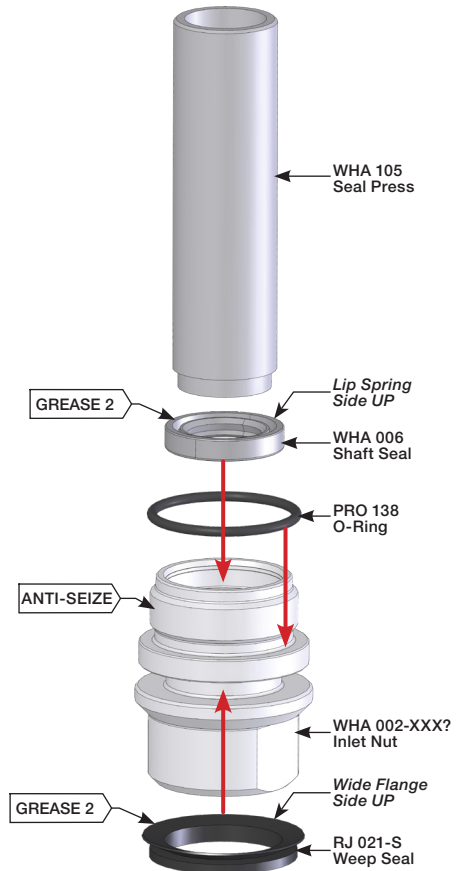

Figure 15: For Steps 3-4

7. Lightly coat the Shaft with grease where the Shaft Seals and Bearings ride.
8. Press Bearings on both sides of the Shaft with an Arbor Press.

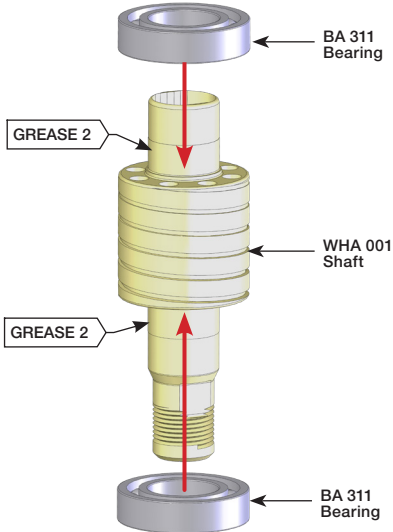

Figure 16: For Steps 7-8

9. Press the Shaft Seal onto the end of the WHA 105 Seal Press Tool with the lip spring facing UP.
10. Push the Seal Press Tool with Seal into the Body until it is seated evenly in the bottom. Then grease the inside diameter of the Seal.

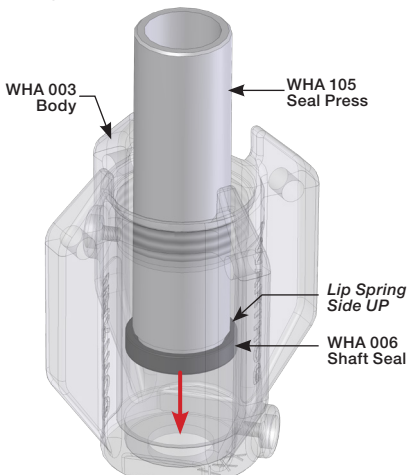

Figure 17: For Steps 9-10

11. Clamp the flats on the Body in a vise and insert the Shaft/Bearing Assembly into the Body with the stem of the Shaft facing DOWN.

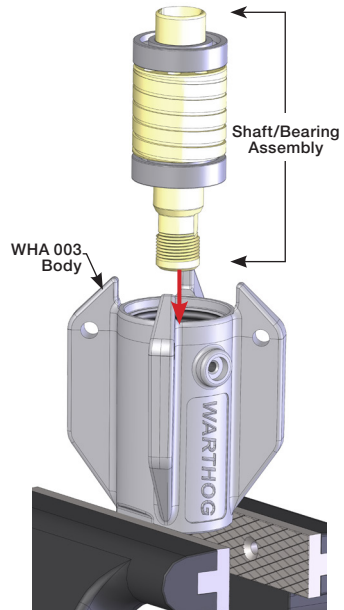

Figure 18: For Step 11

12. Install the Bottom Port Plug (BJ 026) only.

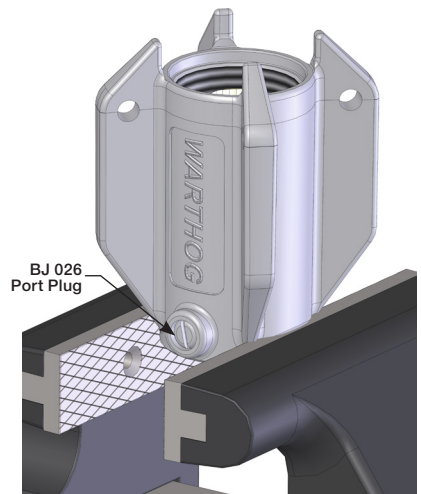

Figure 19: For Step 12

NOTICE

Medium viscosity fluid (*BJ 048-M*) is recommended by StoneAge for maximized performance and Minimized maintenance.

Please contact your Dealer or StoneAge Customer Service to select the right fluid for your application.

- Fill the Body with fluid (*BJ 048-M*) to the bottom of the chamfer of the shoulder on the Shaft.

⚠ This fluid level height is critical.

- Spin the Shaft to bleed the Fluid. Attach the Hex Tool (*WHA 183*) to a 3/8" drive ratchet with a 3" extension and insert it into the internal hex in the end of the Shaft. Rotate the Shaft slowly in a Counterclockwise direction to work out all the air bubbles from the system.

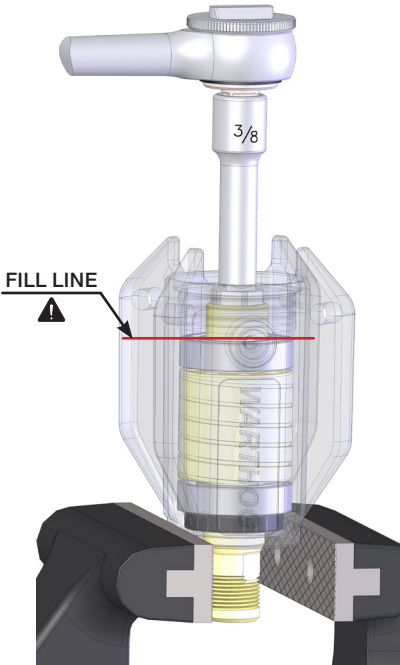

Figure 20: For Steps 13-14

💡 TECH TIP: The viscosity of the fluid is very thick. Be sure to take time to purge the air bubbles.

- Install the top Port Plug (*BJ 026*).
- Press the O-Ring (*WHR 050*) into the groove of the Shaft before the start of the Shaft threads. Grease the O-Ring after installation.
- Place the Wave Spring into the Shaft.
- Apply a light coating of grease to the stem of the Shaft HP Seal. Using the HP Seal Press (*WHR 184*) gently press the Shaft HP Seal into the Shaft. Rocking the Shaft HP Seal in a small circular pattern while applying light pressure may aid in installation. Pressing too hard will damage or chip the seal. Always use the Seal Install Tool to avoid damage to the polished face. The Shaft HP Seal should compress freely into the Shaft and spring return.
- Clean the polished face of the Shaft HP Seal with Isopropyl alcohol. The polished face needs to be clean and free from lint, grease and oils.

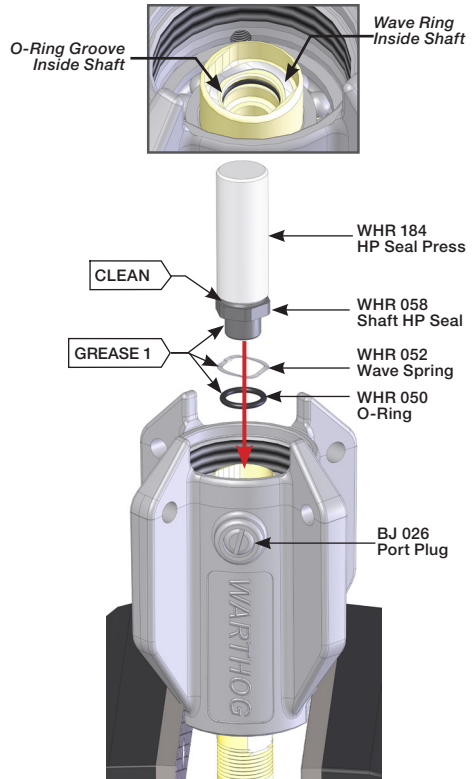

Figure 21: For Steps 15-19

20. Generously coat the Wave Spring with grease. Grease the leading edge of the Shaft and drop the Wave Spring into the Body on top of the Bearing.

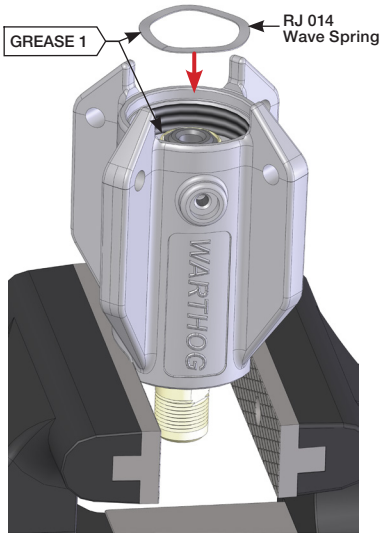

Figure 23: For Step 20

21. Apply anti-seize on the threads of the Inlet Nut. Install the Inlet Nut tightly. (A torque of 115-135 ft-lb. is recommended)
22. Hold the tool at an angle so one of the ports is the highest position, remove the Port Plug to relieve any pressure built up from installing the Inlet Nut then reinstall the Port Plug.

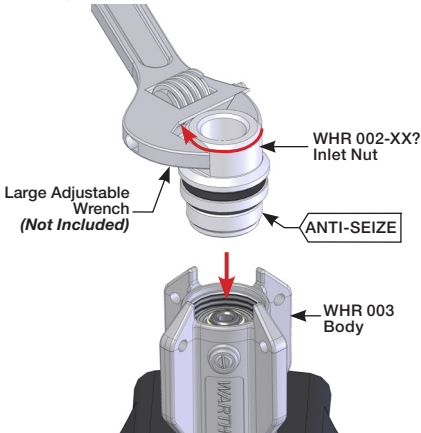

Figure 24: For Steps 21-22

23. Install the Head by clamping the flats in a vise with the threads facing up.
24. Make sure the threads on the Shaft and inside the Head are free from grit and debris. Apply Parker® Yellow ThreadMate and Teflon Tape to the Shaft threads and install into the Head tightly. (A torque of 50 ft-lb. is recommended).

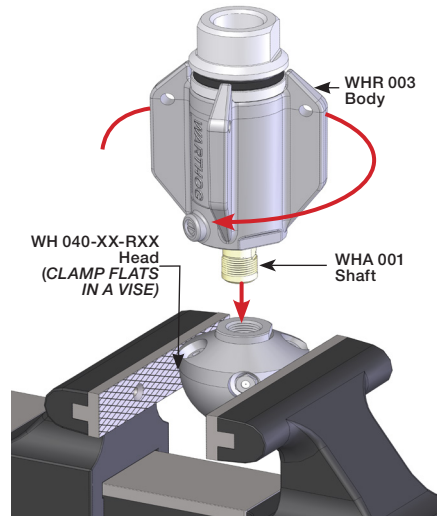

Figure 25: For Step 23

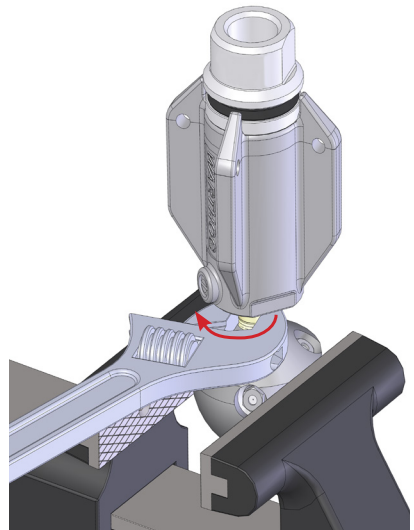
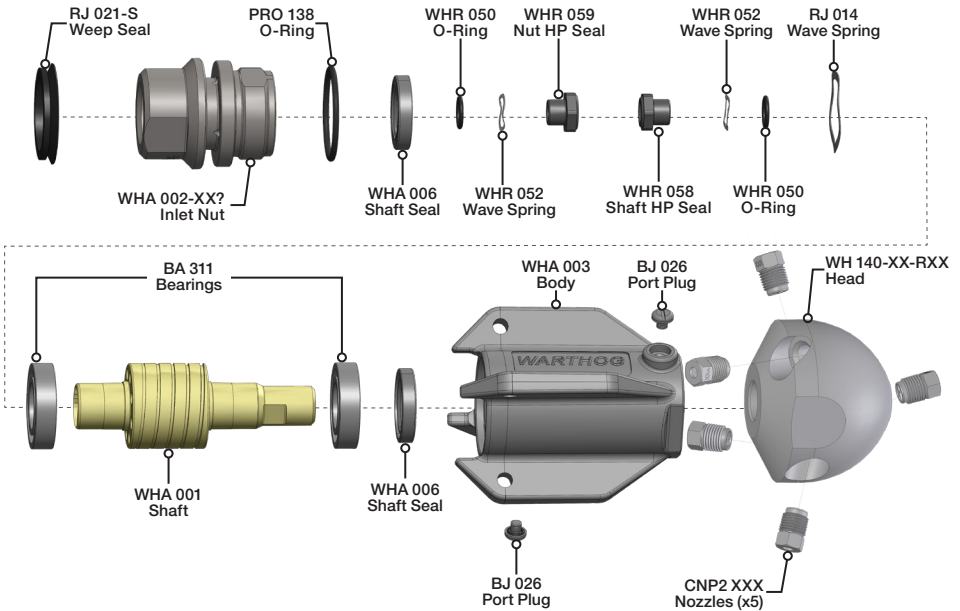

Figure 26: For Step 24

Warthog® PRO (WHA) MAINTENANCE SCHEDULE

ITEM	FREQUENCY	MAINTENANCE REQUIRED
Nozzle	Weekly	<ul style="list-style-type: none"> Rinse the nozzle with clean water to remove debris between the head, body and shaft.
Inserts	Weekly	<ul style="list-style-type: none"> Inspect all inserts for blockages. Remove inserts with blockages and clean and dry them thoroughly. Use thread sealant and ensure inserts are not cross threaded when inserting them back into the head. Install the inserts back into the exact locations from which they were removed to ensure the nozzle remains balanced. If using the nozzle in recycled water, remove inserts and check for the following; Erosion or chipping of the orifice, missing or damaged flow straighteners, and/or visible damage to the insert itself.
Head	Weekly	<ul style="list-style-type: none"> Ensure head is rotating properly; when turned by hand, head should turn free with slight, smooth resistance. If head spins too fast or sounds different than usual, nozzle may be low on viscous fluid or fluid is contaminated. If head feels gritty when turning, flush between head and body. If head still feels gritty when turning, rebuild recommended.
Insert Orifice Size	Every 6 months	<ul style="list-style-type: none"> Inspect insert orifice size with pin gages. Replace inserts as needed to retain most effective jetting capability and cleaning efficiency during operation.
Body	After one Year	<ul style="list-style-type: none"> See “Viscous Fluid Replacement” section of the User Manual. Flush viscous fluid with same type (BJ 048-M). This procedure is <i>only</i> recommended for replacing with the <i>same</i> fluid. Not all of the fluid will be replaced during the flushing procedure, therefore full disassembly and cleaning of the tool is recommended when changing to a different speed, or viscosity of fluid. Full fluid change is necessary when replacing bearings and shaft seals.
Nozzle	After two Years	<ul style="list-style-type: none"> Full disassembly, inspection, and overhaul. See complete Disassembly and Assembly instructions in the User Manual or Maintenance Video. (Links provided below.) Take care throughout the entire procedure to keep the internals clean and free from grit, lint, and contamination. Failure to do so could result in premature failure after service.

Warthog® PRO (WHA) SERVICE KITS



KITS AND KIT CONTENTS

WHA 600-ST1 H.P. SEAL KIT	WHA 610-RT1 OVERHAUL KIT
<ul style="list-style-type: none"> 1 BJA 062-S Copper Antiseize 1.3, 2g Pouch 2 GP 805 Container with Foam 2 WHR 050 O-Ring 2 WHR 052 Wave Spring 1 WHR 058 Shaft HP Seal 1 WHR 059 Nut HP Seal 	<ul style="list-style-type: none"> 2 BA 311 Ball Bearing 2 BJA 026 Port Plug 1 BJA 062-S Copper Antiseize 1.3, 2g Pouch 2 GP 805 Container with Foam 1 PRO 138 O-Ring 1 RJ 014 Wave Spring 1 RJ 021-S Weep Seal 2 WHA 006 Shaft Seal 2 WHR 050 O-Ring 2 WHR 052 Wave Spring 1 WHR 058 Shaft HP Seal 1 WHR 059 Nut HP Seal
WHA 612 TOOL KIT	VS 604-M VISC KIT
<ul style="list-style-type: none"> 1 BA 481 Bearing Removal Tool 1 WGR 186 HP Seal Puller Tool 1 WHA 105 Seal Install Tool 1 WHR 183 Hex Tool 1 WHR 184 HP Seal Install Tool 1 WHR 187 HP Seal Puller Pin 	<ul style="list-style-type: none"> 1 BC 410 Syringe with 6oz of Medium Visc

TERMS AND CONDITIONS AND WARRANTY INFORMATION

1. Acceptance of Terms and Conditions. Receipt of these Terms and Conditions of Sale ("Terms and Conditions") shall operate as the acceptance by StoneAge, Inc. ("Seller") of the order submitted by the purchaser ("Buyer"). Such acceptance is made expressly conditional on assent by Buyer to these Terms and Conditions. Such assent shall be deemed to have been given unless written notice of objection to any of these Terms and Conditions (including inconsistencies between Buyer's purchase order and this acceptance) is given by Buyer to Seller promptly on receipt hereof.

Seller desires to provide Buyer with prompt and efficient service. However, to individually negotiate the terms of each sales contract would substantially impair Seller's ability to provide such service. Accordingly, the product(s) furnished by Seller are sold only according to the terms and conditions stated herein and with the terms and conditions stated in any effective StoneAge Dealer Agreement or StoneAge Reseller Agreement, if applicable. Notwithstanding any terms and conditions on Buyer's order, Seller's performance of any contract is expressly made conditional on Buyer's agreement to these Terms and Conditions unless otherwise specifically agreed to in writing by Seller. In the absence of such agreement, commencement of performance, shipment and/or delivery shall be for Buyer's convenience only and shall not be deemed or construed to be an acceptance of Buyer's terms and conditions.

2. Payment/Prices. Unless other arrangements have been made in writing between Seller and Buyer, payment for the product(s) shall be made upon receipt of invoice. The prices shown on the face hereof are those currently in effect. Prices invoiced shall be per pricelist in effect at the time of shipment. Prices are subject to increase for inclusion of any and all taxes which are applicable and which arise from the sale, delivery or use of the product(s), and the collection of which Seller is or may be responsible to provide to any governmental authority, unless acceptable exemption certificates are provided by Buyer in accordance with applicable law. Buyer shall pay all charges for transportation and delivery and all excise, order, occupation, use or similar taxes, duties, levies, charges or surcharges applicable to the product(s) being purchased, whether now in effect or hereafter imposed by any governmental authority, foreign or domestic.

3. Warranty. SELLER MAKES NO WARRANTIES OR REPRESENTATIONS AS TO THE PERFORMANCE OF ANY PRODUCT EXCEPT AS SET FORTH IN THE STONEAGE LIMITED WARRANTY PROVIDED WITH THE PRODUCT.

4. Delivery. Seller is not obligated to make delivery by a specified date, but will always use its best efforts to make delivery within the time requested. The proposed shipment date is an estimate. Seller will notify Buyer promptly of any material delay and will specify the revised delivery date as soon as practicable. UNDER NO CIRCUMSTANCES SHALL SELLER HAVE ANY LIABILITY WHATSOEVER FOR LOSS OF USE OR FOR ANY DIRECT OR CONSEQUENTIAL DAMAGES RESULTING FROM DELAY REGARDLESS OF THE REASON(S).

All product(s) will be shipped F.O.B. point of origin, unless specifically agreed otherwise, and Buyer shall pay all shipping costs and insurance costs from that point. Seller, in its sole discretion, will determine and arrange the means and manner of transportation of the product(s). Buyer shall bear all risk of loss commencing with the shipment or distribution of the product(s) from Seller's warehouse. Order shortages or errors must be reported within fifteen (15) business days from receipt of shipment to secure adjustment. No product(s) may be returned without securing written approval from Seller.

5. Modification. These Terms and Conditions are intended by Seller and Buyer to constitute a final, complete and exclusive expression of agreement relating to the subject matter hereof and cannot be supplemented or amended without Seller's prior written approval.

6. Omission. Seller's waiver of any breach or Seller's failure to enforce any of these Terms and Conditions at any time, shall not in any way affect, limit or waive Seller's right thereafter to enforce and compel strict compliance with every term and condition hereof.

7. Severability. If any provision of these Terms and Conditions is held to be invalid or unenforceable, such invalidity or unenforceability shall not affect the validity or enforceability of the other portions hereof.

8. Disputes. Seller and Buyer shall attempt in good faith to promptly resolve any dispute arising under these Terms and Conditions by negotiations between representatives who have authority to settle the controversy. If unsuccessful, Seller and Buyer shall further attempt in good faith to settle the dispute by nonbinding third-party mediation, with fees and expenses of such mediation apportioned equally to each side. Any dispute not so resolved by negotiation or mediation may then be submitted to a court of competent jurisdiction in accordance with the terms hereof. These procedures are the exclusive procedures for the resolution of all such disputes between the Seller and Buyer.

TERMS AND CONDITIONS AND WARRANTY INFORMATION

9. Governing Law. All sales, agreements for sale, offers to sell, proposals, acknowledgments and contracts of sale, including, but not limited to, purchase orders accepted by Seller, shall be considered a contract under the laws of the State of Colorado and the rights and duties of all persons, and the construction and effect of all provisions hereof shall be governed by and construed according to the laws of such state.

10. Jurisdiction and Venue. Seller and Buyer agree that the state or federal courts located within the City and County of Denver, Colorado shall have sole and exclusive jurisdiction over any litigation concerning any dispute arising under these Terms and Conditions not otherwise resolved pursuant to Section 9 as well as any alleged defects of any Products or damages sustained as a result of such alleged defects. Seller and Buyer further agree that should any litigation be commenced in connection with such a dispute, it shall only be commenced in such courts. Seller and Buyer agree to the exclusive jurisdiction of such courts and neither will raise any objection to the jurisdiction and venue of such courts, including as a result of inconvenience.

11. Attorney's Fees. If any litigation is commenced between Seller and Buyer, or their personal representatives, concerning any provision hereof, the party prevailing in the litigation shall be entitled, in addition to such other relief that is granted, to a reasonable sum as and for their attorneys' fees and costs in such litigation or mediation.

STONEAGE TRADEMARK LIST

View the list of StoneAge's trademarks and service marks and learn how the trademarks should be used. Use of StoneAge trademarks may be prohibited, unless expressly authorized.

<http://www.StoneAgetools.com/trademark-list/>

STONEAGE PATENT DATA

View the list of StoneAge's current U.S. patent numbers and descriptions.

[PAT http://www.sapatents.com](http://www.sapatents.com)

STONEAGE TERMS AND WARRANTY

View StoneAge's Terms and Warranty Conditions online.

<http://www.stoneagetools.com/terms>

<http://www.stoneagetools.com/warranty>

TERMS AND CONDITIONS AND WARRANTY INFORMATION

WARRANTY:

Warranties set forth herein extend only to End-Users, meaning customers acquiring, or that have previously acquired, a product manufactured by StoneAge ("Product") for their own use and not for resale, either directly from StoneAge Inc. ("StoneAge") or from a StoneAge Authorized Dealer or Reseller ("Dealer"). No warranty of any kind or nature is made by StoneAge beyond those expressly stated herein.

1. LIMITED WARRANTY PERIOD. Subject to the limitations and conditions hereinafter set forth, StoneAge warrants its Product to be free from defects in workmanship and material for a period of one (1) year from the date of purchase by the End-User, provided that the end of the limited warranty period shall not be later than eighteen (18) months from the date of shipment of the Product to the Dealer or the End-User by StoneAge ("Limited Warranty Period"). All replacement parts which are furnished under this Limited Warranty and properly installed shall be warranted to the same extent as the original Product under this Limited Warranty if, and only if, the original parts were found to be defective within the original Limited Warranty Period covering the original Product. Replacement parts are warranted for the remainder of the original Limited Warranty Period. This Limited Warranty does not cover any component part of any Product not manufactured by StoneAge. Any such component part is subject exclusively to the component manufacturer's warranty terms and conditions.

2. LIMITED WARRANTY COVERAGE. StoneAge's sole obligation under this Limited Warranty shall be, at StoneAge's option and upon StoneAge's inspection, to repair, replace or issue a credit for any Product which is determined by StoneAge to be defective in material or workmanship. StoneAge reserves the right to examine the alleged defective Product to determine whether this Limited Warranty is applicable, and final determination of limited warranty coverage lies solely with StoneAge. No statement or recommendation made by a StoneAge representative, Dealer or agent to End-User shall constitute a warranty by StoneAge or a waiver or modification to any of the provisions hereof or create any liability for StoneAge.

3. WARRANTY SERVICE PROVIDERS. Service and repair of the Product is to be performed only by StoneAge authorized service representatives, including Dealers who are authorized repair centers, with StoneAge approved parts. Information about StoneAge authorized service representatives can be obtained through the StoneAge website at www.stoneagetools.com/ service. Unauthorized service, repair or modification of the Product or use of parts not approved by StoneAge will void this Limited Warranty. StoneAge reserves the right to change or improve the material and design of the Product at any time without notice to End-User, and StoneAge is not obligated to make the same improvements during warranty service to any Product previously manufactured.

4. WARRANTY EXCLUSIONS. This Limited Warranty does not cover, and StoneAge shall not be responsible for the following, or damage caused by the following: (1) any Product that has been altered or modified in any way not approved by StoneAge in advance in writing; (2) any Product that has been operated under more severe conditions or beyond the rated capacity specified for that Product; (3) depreciation or damage caused by normal wear and tear, failure to follow operation or installation instructions, misuse, negligence or lack of proper protection during storage; (4) exposure to fire, moisture, water intrusion, electrical stress, insects, explosions, extraordinary weather and/or environmental conditions including, but not limited to lightning, natural disasters, storms, windstorms, hail, earthquakes, acts of God or any other force majeure event; (5) damage to any Product caused by any attempt to repair, replace, or service the Product by persons other than StoneAge authorized service representatives; (6) costs of normal maintenance parts and services; (7) damage sustained during unloading, shipment or transit of the Product; or (8) failure to perform the recommended periodic maintenance procedures listed in the Operator's Manual accompanying the Product.

5. REQUIRED WARRANTY PROCEDURES. To be eligible for warranty service, the End-User must: (1) report the Product defect to the entity where the Product was purchased (i.e. StoneAge or the Dealer) within the Limited Warranty Period specified in this Limited Warranty; (2) submit the original invoice to establish ownership and date of purchase; and (3) make the Product available to a StoneAge authorized service representative for inspection to determine eligibility for coverage under this Limited Warranty. This Limited Warranty shall not extend to any person or entity who fails to provide proof of original purchase from StoneAge or a Dealer. No Product may be returned for credit or adjustment without prior written permission from StoneAge.

6. DISCLAIMER OF IMPLIED WARRANTIES AND OTHER REMEDIES. EXCEPT AS EXPRESSLY STATED HEREIN (AND TO THE FULLEST EXTENT ALLOWED UNDER APPLICABLE LAW), STONEAGE HEREBY DISCLAIMS ALL OTHER WARRANTIES, EXPRESS OR IMPLIED, INCLUDING WITHOUT LIMITATION ALL IMPLIED WARRANTIES OF MERCHANTABILITY OR FITNESS FOR A PARTICULAR PURPOSE, AND ANY AND ALL WARRANTIES, REPRESENTATIONS OR PROMISES AS TO THE QUALITY, PERFORMANCE OR FREEDOM FROM DEFECT OF THE PRODUCT COVERED BY THIS LIMITED WARRANTY. STONEAGE FURTHER DISCLAIMS ALL IMPLIED INDEMNITIES.

TERMS AND CONDITIONS AND WARRANTY INFORMATION

7. LIMITATION OF LIABILITY. End-User specifically acknowledges that the Product may be operated at high speeds and/or pressures, and that as such it may be inherently dangerous if not used correctly. End-User shall familiarize itself with all operation materials provided by StoneAge and shall at all times use and require its agents, employees and contractors to use all necessary and appropriate safety devices, guards and proper safe operating procedures. In no event shall StoneAge be responsible for any injuries to persons or property caused directly or indirectly by the operation of the Product if End-User or any agent, employee, or contractor of End-User: (1) fails to use all necessary and appropriate safety devices, guards and proper safe operating procedures; (2) fails to maintain in good working order such safety devices and guards; (3) alters or modifies the Product in any way not approved by StoneAge in advance in writing; (4) allows the Product to be operated under more severe conditions or beyond the rated capacity specified for the Product; or (5) otherwise negligently operates the Product. End-User shall indemnify and hold StoneAge harmless from any and all liability or obligation incurred by or against StoneAge, including costs and attorneys' fees, to or by any person so injured.

TO THE FULL EXTENT ALLOWED BY APPLICABLE LAW, STONEAGE SHALL NOT BE LIABLE FOR ANY INDIRECT, SPECIAL, INCIDENTAL, CONSEQUENTIAL, OR PUNITIVE DAMAGES (INCLUDING WITHOUT LIMITATION, LOSS OF PROFITS, LOSS OF GOODWILL, DIMINUTION OF VALUE, WORK STOPPAGE, INTERRUPTION OF BUSINESS, RENTAL OF SUBSTITUTE PRODUCT, OR OTHER COMMERCIAL LOSS EVEN TO THE EXTENT SUCH DAMAGES WOULD CONSTITUTE DIRECT DAMAGES), WITH RESPECT TO THE COVERED STONEAGE PRODUCT, OR OTHERWISE IN CONNECTION WITH THIS LIMITED WARRANTY, REGARDLESS OF WHETHER STONEAGE HAS BEEN ADVISED OF THE POSSIBILITY OF SUCH DAMAGES.

IT IS UNDERSTOOD THAT STONEAGE'S LIABILITY, WHETHER IN CONTRACT, IN TORT, UNDER ANY WARRANTY, IN NEGLIGENCE, OR OTHERWISE SHALL NOT EXCEED THE AMOUNT OF THE PURCHASE PRICE PAID BY THE END-USER FOR THE PRODUCT. STONEAGE'S MAXIMUM LIABILITY SHALL NOT EXCEED, AND END-USER'S REMEDY IS LIMITED TO EITHER (1) REPAIR OR REPLACEMENT OF THE DEFECTIVE WORKMANSHIP OR MATERIAL OR, AT STONEAGE'S OPTION, (2) REFUND OF THE PURCHASE PRICE, OR (3) ISSUANCE OF A CREDIT FOR THE PURCHASE PRICE, AND SUCH REMEDIES SHALL BE END-USER'S ENTIRE AND EXCLUSIVE REMEDY.

YOU, THE END-USER, UNDERSTAND AND EXPRESSLY AGREE THAT THE FOREGOING LIMITATIONS ON LIABILITY ARE PART OF THE CONSIDERATION IN THE PRICE OF THE STONEAGE PRODUCT YOU PURCHASED.

Some jurisdictions do not allow the limitation or exclusion of liability for certain damages, so the above limitations and exclusions may not apply to you. This Limited Warranty gives you specific legal rights, and you may also have other rights which vary from jurisdiction to jurisdiction. If any provisions of this Limited Warranty is held to be invalid or unenforceable, such invalidity or unenforceability shall not affect the validity or enforceability of the other portions hereof.

PAGE LEFT BLANK INTENTIONALLY

PAGE LEFT BLANK INTENTIONALLY



1-866-795-1586 • www.STONEAGETOOLS.com

© 2023 StoneAge, Inc. All Rights Reserved